

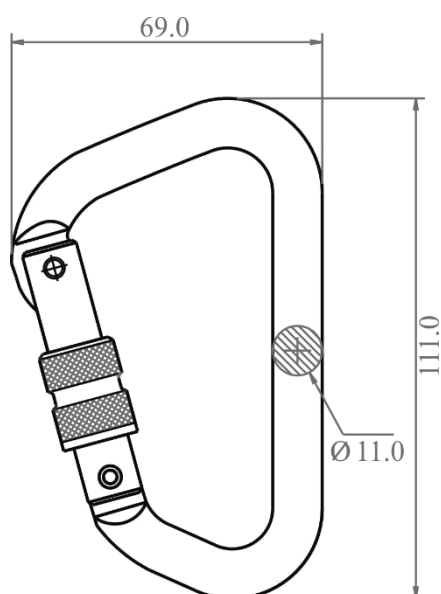

# TECHNICAL SHEET FA 50 103 22

## ALUMINUM SCREW-LOCKING KARABINER



Opening :	<b>CE</b>	Weight:
22,5 mm		0,08 kg

### KRATOS SAFETY

689 Chemin du Buclay  
38540 Heyrieux – FRANCE

Tel : +33 (0)4 72 48 78 27

Fax : +33 (0)4 72 48 58 32

[www.kratossafety.com](http://www.kratossafety.com) / [info@kratossafety.com](mailto:info@kratossafety.com)

### Aluminum screw-locking karabiner

- Opening: 21 mm
- Minimum breaking strength: 23 kN
- Compliance :  
EN362 : 2004 Class B,  
EN13463-1:2009, EN13463-5:2003 - ATEX :  
II2GcT6

**Material of components:** Aluminum Alloy

#### HS CODE

7616 99 90

#### CARTON SIZE / PCS.

60 x 40 x 24 / 200

#### AET N° 2006 I4 E4

Satra Technology Centre, N°0321  
Wyndham Way, Telford Way, Kettering  
Northamptonshire, NN16 8SD, United Kingdom

#### ARTICLE 11 GB07/73551

SGS United Kingdom Ltd., N°0120  
Unit 202B, Worle Parkway,  
Weston-super-Mare, BS22 6WA, United Kingdom